



# PILOT'S MANUAL

HAPPY RESCUE SYSTEM  
H32  
H35  
H50



CERTIFICATION ULL-01/95





# CONTENTS

1. Introduction
2. Pre flight
3. Care and maintenance
4. Storage
5. Drying and airing
6. Cleaning
7. Packing
8. Repacking
9. Warranty
10. Repairs
11. Technical informations
12. About Axis

THANK YOU FOR TAKING THE  
TIME TO READ THIS BOOKLET

# INTRODUCTION



Axis have a 10 year history in parachute design and have employed their years of knowledge and expertise in the design and construction of the paragliding reserve system Happy.

**Happy reserve consists of** canopy with lines, inner container, connecting bridle strap and release handle.

Happy is based on the pull-down apex design. The canopy is reinforced so that it is resistant even to the dynamic impact after a free fall.

The pull-down apex central line reduces opening time and improves the sink rate whilst the inner container is designed so that all the suspension lines are attached to container by rubber bands so there is no danger of entanglement of lines or canopy during deployment.

**Happy** is designed only for use in an emergency situation on a paraglider, it is unsuitable for free fall parachuting.

This manual provides information about the Happy reserve system, which will help you to fly safely and keep your equipment in good condition. If after reading this manual you have any further questions, please don't hesitate to contact us or any authorised Axis dealer.

Thank you for choosing the Happy from **Axis**.

# PRE FLIGHT



For your safety, always use a consistent system of pre-flight checks for all your equipment and repeat the same sequence before every flight.

Specifically with your reserve parachute, check that:

- There is no visible damage that could affect its airworthiness.
- The reserve parachute container is closed correctly with the pin or pins in place.
- The employment handle is secured correctly to your harness

If any part of your harness / reserve/ handle system includes Velcro, you should separate and re-attach these pieces regularly.

Velcro 'beds-in' over time which could make deploying your reserve difficult.

# CARE AND MAINTENANCE



We recommend that **Happy** should be inspected and repacked at least every 6 months by a trained professional repacker.

If you feel there may be the likelihood of damage or wear, additional inspections should be carried out.

After a deployment, the reserve must be checked by the distributor or manufacturer.

The materials used in Happy have been carefully selected for maximum durability. Nevertheless, maintaining your reserve following the guidelines below will extend its lifetime.

It is recommended that any reserve system is replaced after 10 years, even if it has never been used.

INSPECTED AND  
REPACKED AT  
LEAST EVERY 6  
MONTHS

# STORAGE



Due to the specific purpose of the reserve system you should pay careful attention to its storage and packing. If you need to store your reserve long-term, it should be unpacked and loosely rolled in a closed bag.

Be careful to avoid any possible contact with harmful substances such as oils, grease, acids, paint etc.

Your reserve should always be stored away from contact with UV radiation (sunlight).

## DRYING AND AIRING

If your reserve gets wet, you should remove it from the harness. Dry it naturally in the air, and have it repacked before putting it back into the container.

Take care to avoid contact by sunlight while the reserve is drying

If the canopy shows any sign of mildew or mould, it must be sent to the distributor or manufacturer for checking, as its strength could be compromised.

# CLEANING



Oils, grease, paint and other chemicals can seriously damage and weaken the structure of reserve system.

If your reserve becomes contaminated by any such agent the whole reserve system must be sent back to the manufacturer for a thorough inspection.

A dirty reserve canopy or container can be cleaned with lukewarm water. Mild, neutral soap may be used on the container if necessary.

Always rinse the canopy thoroughly in fresh, clean water and allow it to dry naturally.

# PACKING

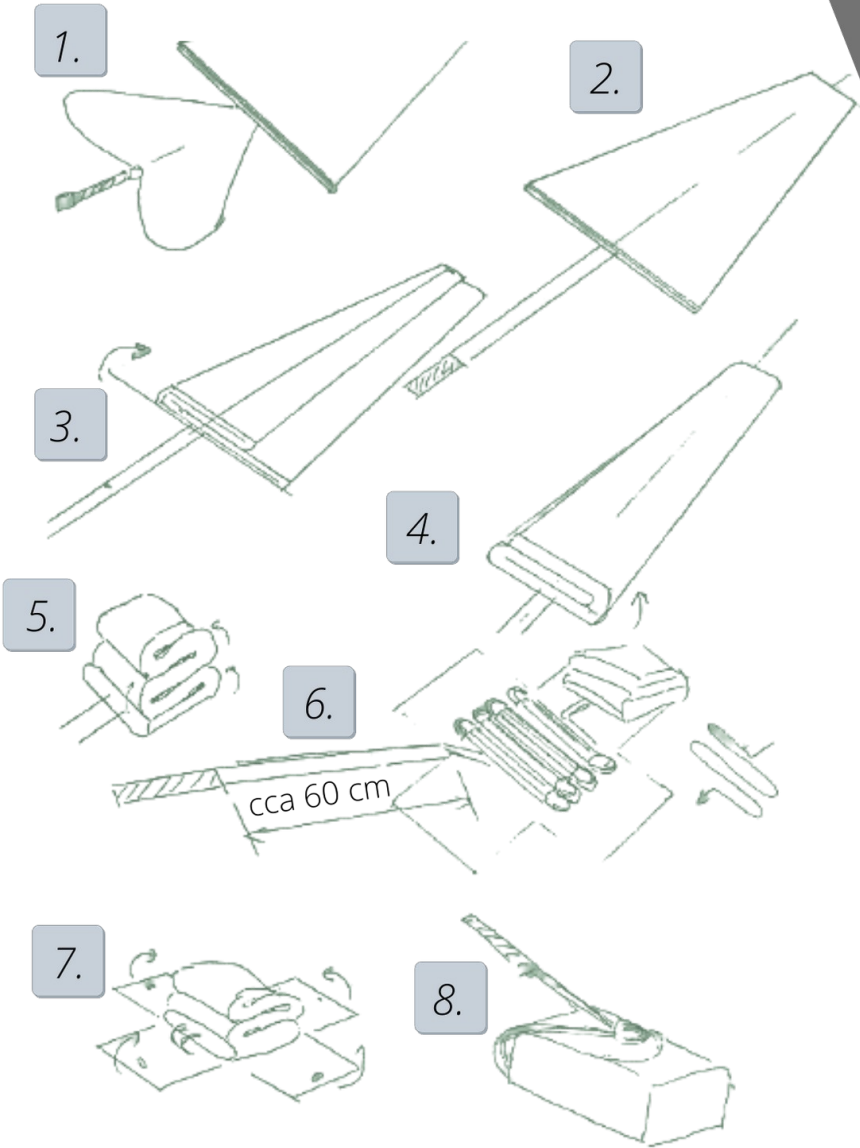



# REPACKING



Please be aware that the reliability of any reserve parachute system is significantly affected by how it is packed. We strongly recommend that you only use only trained qualified re-packers or the manufacturer for this important task.

You should always have the reserve system inspected by the manufacturer in the event of any of the following:

- After deploying the reserve, even in controlled or training purpose
- After any damage or alteration of the system
- Within 2 years of the previous manufacturers inspection.

Failure to do so may invalidate the warranty. The warranty card should be sent with the reserve system at each inspection.

# WARRANTY CONDITIONS



The warranty is valid for a period of 3 years provided all the manufactures recommendations are followed.

However from our wide experience, if the reserve system is used properly and checked in accordance with these recommendations the warranty period can be extended.

Extension periods of 1 year may be granted by the manufacturer after a thorough inspection of the reserve system

## REPAIRS

All repairs must be carried out by the manufacturer.

# TECHNICAL INFORMATION

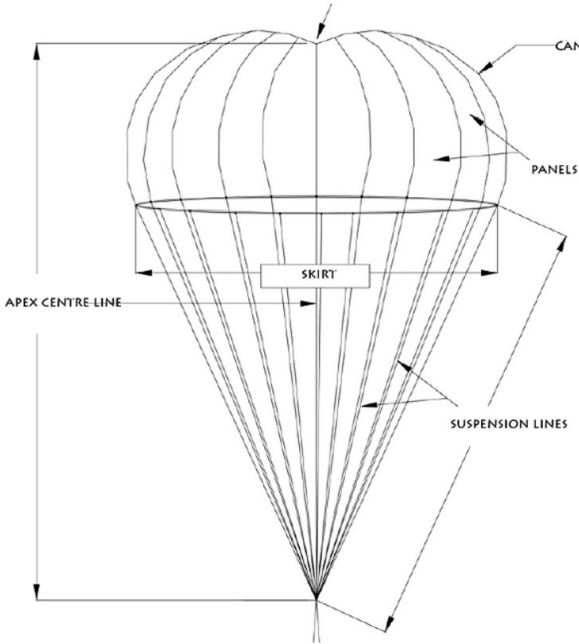

**SIZE**

**H32**

**H35**

**H50**

**PROJECTED AREA (M2)**

**31,6**

**34,7**

**49,8**

**NUMBER OF PANELS**

**20**

**22**

**22**

**WEIGHT (KG)**

**1,7**

**1,85**

**2,7**

**SINK RATE (M/S)**

**5.0**

**5.0**

**5.0**

**WEIGHT RANGE (KG)**

**UP TO 100**

**UP TO 130**

**UP TO 250**

**CERTIFICATION**

**No. ULL - 01 / 95**

# ABOUT AXIS



Success swiftly followed and now many of the world's best competition pilots choose to fly Axis. They have won podium places at competitions around the world, including at recent World Cup events and the World Championships.

The lessons learned from these thousands of hours of testing gliders and competition success' have been used in the development of the Happy reserve system.

All our test pilots use the Happy reserve system while testing our prototype and new paragliders.

We welcome feedback from you about your new Happy reserve system. Send it to us at [info@axispara.cz](mailto:info@axispara.cz)

Please note  
We have made every effort to ensure that the information in this manual is correct, but please remember it is for guidance only.

The manual is subject to change without prior notice. Check the websites for updates and the latest information regarding **Axis products**.

**Date of repacking**

**Signature**

**Type :**

**Serial number :**

**Manufacturing date :**



**Axispara HQ**

**Airport Brno - Medlánky**

**Turistická street**

**621 00 Brno**

**Czech republic**



**+420 601 52 66 74**



**[www.axispara.cz](http://www.axispara.cz)**



**[info@axispara.cz](mailto:info@axispara.cz)**



**Axis paragliders**



**@axisparagliders**

**Contact your local dealer**

**[www.axispara.cz/dealers](http://www.axispara.cz/dealers)**

**AXIS**  
**PARAGLIDERS**